

# LSE445/NSE300/400

GÜVENİLİR VE VERİMLİ İŞLEME İÇİN 20° POZİTİF KESİCİ  
UÇLU GENEL YÜZEY FREZELEME SERİSİ



*M*plus...

# LSE445



## 45° YÜZEY FREZELEME - GENEL KESME

P M K N



C H:45°  
A.R:+19° T:+13°  
RR:-2° I:+15°

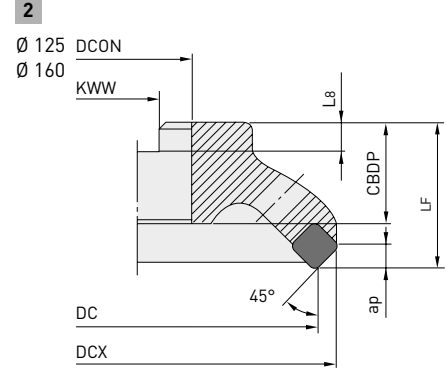
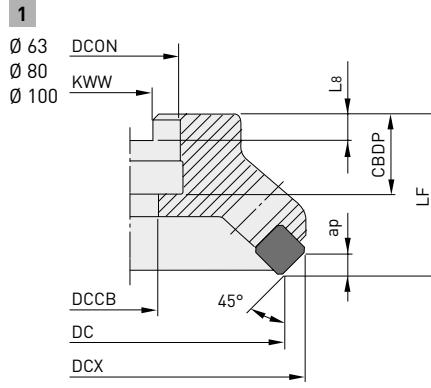

### MALAFİ TİPİ

Sipariş Numarası	Stok		ZEFP	DC	DCX	LF	DCON	CBDP	DCCB	KWW	L8	WT	APMX	Tip
	R	L												
LSE445-063A05R/L-E	●	□	5	63	76.5	40	22	20	11	10.4	6.4	0.8	5.5	1
LSE445-080A06R/L-E	●	□	6	80	93.5	50	27	22	13.5	12.4	7.0	1.0	5.5	1
LSE445-100A07R/L-E	●	□	7	100	113.5	50	32	25	17.5	14.4	8.0	1.4	5.5	1
LSE445-125B09R/L-E	□	□	9	125	138.5	50	40	32	—	16.4	9.0	2.0	5.5	2
LSE445-160B11R/L-E	□	□	11	160	173.5	50	40	32	—	16.4	9.0	3.0	5.5	2



## YEDEK PARÇALAR

Takım Tutucu Numarası	Altlık	Altlık Vidası	Kama	Sıkma Vidası	Anahtar	Anahtar
LSE445-063A05R/L-E				LS10T		
LSE445-080A04R/L-E						
LSE445-100A07R/L-E	STBE445NF	CS300890T	CWSE445TR	LS15T	TKY25T	TKY08F
LSE445-125B09R/L-E						
LSE445-160B11R/L-E						

\*1 Sıkma Torku (N • m): LS10T=8.5. LS15T=8.5. CS300890T=1.0

# KESİCİ UÇLAR

P	Çelik	●	●	●	●	●	●	●	●								Kesme Koşulları:
M	Paslanmaz Çelik	●	●	●	●	●	●	●	●								●:Düz stabil Kesme ●:Genel Kesme ✚:Darbeli Kesme
K	Dökme Demir			●	✚	●		✚	●								Honlama:
N	Demir İçermeyen Metal								●								E:Yuvarlak F:Keskin S:Pah + Hon T:Şamfer Z:Güçlü

Sipariş Numarası	Sınıf	Honlama	F7010	F7030	MC5020	VP15TF	NX2525	NX4545	UT120T	HT110	IC	S	BS	RE	Şekil
SECN1203AFTN1	C	T						★			12.7	3.18	1.4	1.0	
SEEN1203AFFN1	E	F							●		12.7	3.18	1.4	1.0	
SEEN1203AFEN1	E	E				●					12.7	3.18	1.4	1.0	
SEEN1203AFTN1	E	T	●				●	●	●		12.7	3.18	1.4	1.0	
SEEN1203AFTN3	E	T	●					●	★		12.7	3.18	1.4	—	
SEEN1203AFSN1	E	S		●	●						12.7	3.18	1.4	1.0	
SEEN1203AFSN3	E	S		●							12.7	3.18	1.4	—	
SEEN1203AFZN1	E	Z					●				12.7	3.18	1.4	1.0	

## Kırıclı kesici uçlar

SEER1203AFEN-JS	E	E	●	●	●	●					12.7	3.18	1.4	1.0	
SEER1204AFEN-JS	E	E	●								12.7	3.18	1.4	1.0	

## Silicili kesici uçlar

WEC42AFTR5C	C	T					●				—	3.18	5	1.0	
-------------	---	---	--	--	--	--	---	--	--	--	---	------	---	-----	--

# LSE445

## ÖNERİLEN KESME KOŞULLARI

Çalışma Malzemesi	Sertlik	Kalite	Vc	fz
P Yumuşak Çelik	<180HB	F7030	300 (200-360)	0.2 (0.1-0.3)
		NX4545		
		UTi20T	240 (170-300)	
		UP20M		
Karbon Çeliği Alaşımlı Çelik	180-280HB	F7030	250 (170-300)	0.2 (0.1-0.3)
		NX4545		
		UTi20T	200 (140-240)	
		UP20M		
280-350HB	UTi20T	140 (100-170)	0.15 (0.1-0.2)	
M Paslanmaz Çelik	<200HB	UP20M	200 (140-240)	0.2 (0.1-0.3)
		UTi20T		
K Dökme Demir	Kopma Mukavemeti <450MPa	MC5020	200 (130-240)	0.2 (0.1-0.3)
		F5010		
		F5020	160 (110-190)	
		HTi10		
UTi20T				
N Alüminyum Alaşımı	—	MD220	1000 (200-1500)	0.15 (0.05-0.25)
		HTi10	1000 (700-1200)	0.12 (0.05-0.2)

1. Devir ( $dk^{-1}$ ) =  $(1000 \times \text{Kesme Hızı}) / (3.14 \times veD1)$

2. Tabla İlerlemesi (mm/dk) =  $\text{Diş Başına ilerleme} \times \text{Diş Sayısı} \times \text{Kesici Devri}$



# NSE300/400



## 90° YÜZEY FREZELEME - GENEL KESME

**P M K N**



C H:0°  
A.R:+16° T:+5°-+8°  
R.R:+5°-+8° l:+16°

1

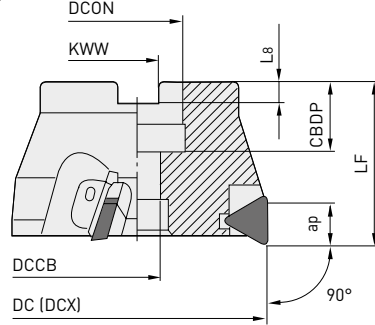

2

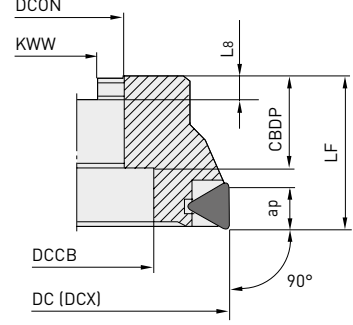

3

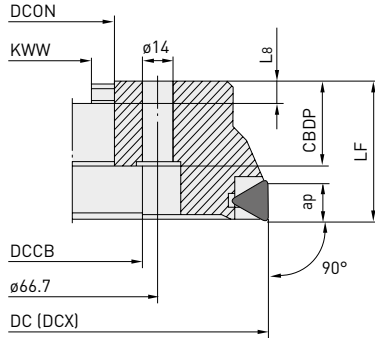

Sağ takım gösterilmiştir.

### MALAFİ TİPİ

Sipariş Numarası	Stok	ZEFP	DC	DCX	LF	DCON	CBDP	DCCB	KWW	L8	WT	APMX	Tip
NSE300-050A04R-E	●	4	50	50	40	22	20	11	10.4	6.3	0.3	12.5	1
NSE300-063A05R-E	●	5	63	63	40	22	20	11	10.4	6.3	0.5	12.5	1
NSE300-080A06R-E	●	6	80	80	50	27	22	13.5	12.4	7	1.1	12.5	1
NSE300-100A08R-E	●	8	100	100	50	32	25	17.5	14.4	8	2.1	12.5	1
NSE300-125B10R-E	●	10	125	125	63	40	32	56	16.4	9	3.2	12.5	2
NSE300-160C12R-E	□	12	160	160	63	40	29	56	16.4	9	5.4	12.5	3
NSE400-080A06R-E	□	6	80	80	50	27	22	13.5	12.4	7	1.1	17	1
NSE400-100A07R-E	□	7	100	100	50	32	25	17.5	14.4	8	2.1	17	1
NSE400-125B08R-E	□	8	125	125	63	40	32	56	16.4	9	3.2	17	2
NSE400-160C10R-E	□	10	160	160	63	40	29	56	16.4	9	5.4	17	3



### YEDEK PARÇALAR







Takım Tutucu Numarası	Konulandırıcı	Anahtar-T	Konulandırıcı	Anahtar-T	Sıkma Vidası	Konulandırıcı Vidası	Anahtar (Sıkma Vidası)	Anahtar (Ayrı Olarak Satılır)
NSE300-050A04R-E		CWTSE300TR			LS19T		TKY15T	
NSE300-063A05R-E	SPTSE300R							
NSE300-080A06R-E		CWNSE300TR			LS10T	TS32		TKY08F
NSE300-160C12R-E							TKY25T	
NSE400-E			SPTSE400R	CWSE300TR	LS10TS			

\* Sıkma Torku (N • m): LS10T=8.5. LS10TS=8.5. LS19T=5.0. TS32=1.0

● : Avrupa da standart stok. □ : Sadece sipariş üzerine üretilir.

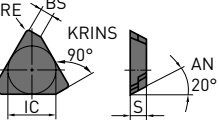
# KESİCİ UÇLAR

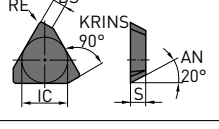
P	Çelik	●	●	●	●	●	●	●	●	Kesme Koşulları :
M	Paslanmaz Çelik	●	●	●	●	●	●	●	●	●:Düz stabil Kesme ●:Genel Kesme ✖:Darbeli Kesme
K	Dökme Demir	●	✖	●	●	●	●	●	●	Honlama:
N	Demir İçermeyen Metal	●	●	●	●	●	●	●	●	E:Yuvarlak F:Keskin S:Pah + Hon T:Şamfer Z:Güçlü

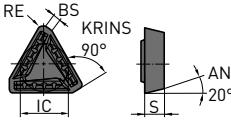
Sipariş Numarası	Sınıf	Honlama	F7030	MC5020	VP15TF	UP20M	NX2525	NX4545	UT120T	HT10	IC	S	BS	RE	Şekil
TECN1603PEFR1W	C	F								★	9.525	3.175	1.4	0.4	
TECN1603PEER1W	C	E								★	9.525	3.175	1.4	0.4	
TECN1603PETR1W	C	T					★	★	★		9.525	3.175	1.4	0.4	
TEEN1603PEFR1	E	F								●	9.525	3.175	1.4	0.4	
TEEN1603PEER1	E	E								●	9.525	3.175	1.4	0.4	
TEEN1603PETR1	E	T				●	●	●	●		9.525	3.175	1.4	0.4	
TEEN1603PESR1	E	S	●	●							9.525	3.175	1.4	0.4	
TEEN1603PEZR1	E	Z					●				9.525	3.175	1.4	0.4	
TECN2204PEFR1	C	F								★	12.7	4.76	1.4	1.0	
TECN2204PETR1	C	T							★		12.7	4.76	1.4	1.0	
TEEN2204PEFR1	E	F								●	12.7	4.76	1.4	1.0	
TEEN2204PEER1	E	E			★					●	12.7	4.76	1.4	1.0	
TEEN2204PETR1	E	T				●	★	●	●		12.7	4.76	1.4	1.0	
TEEN2204PESR1	E	S	●	●							12.7	4.76	1.4	1.0	
<b>Kırıclı kesici uçlar</b>															
TEER1603PEER-JS	E	E	●							●	9.525	3.175	1.4	0.4	
TEER2204PEER-JS	E	E	●						★		12.7	4.76	1.4	1.0	

# NSE300/400

## ÖNERİLEN KESME KOŞULLARI

Çalışma Malzemesi	Sertlik	Kalite	Vc	fz
P Yumuşak Çelik	<180HB	F7030	240 (160-290)	0.2 (0.1-0.3)
		NX4545		
		UTi20T	190 (125-230)	
		UP20M		
P Karbon Çeliği Alaşımlı Çelik	180-280HB	F7030	200 (135-240)	0.2 (0.1-0.3)
		NX4545		
		UTi20T	160 (110-190)	
		UP20M		
M Paslanmaz Çelik	<200HB	UTi20T	110 (80-135)	0.15 (0.1-0.2)
		UP20M		
K Dökme Demir	Kopma Mukavemeti <450MPa	MC5020	200 (130-240)	0.2 (0.1-0.3)
		F5010		
		F5020	160 (110-190)	
		HTi10		
N Alüminyum Alaşımı	-	UTi20T	1000 (200-1500)	0.15 (0.05-0.25)
		MD220		
		HTi10	800 (560-960)	0.12 (0.05-0.2)

1. Devir (dk<sup>-1</sup>) = (1000×Kesme Hızı)÷(3.14×veD1)

2. Tabla İlerlemesi (mm / dk) = Diş Başına İlerleme × Diş Sayısı × Kesici Devri





#### GERMANY

MMC HARTMETALL GMBH  
Comeniusstr. 2 . 40670 Meerbusch  
Phone +49 2159 91890 . Fax +49 2159 918966  
Email admin@mmchg.de

#### U.K.

MMC HARDMETAL U.K. LTD.  
Mitsubishi House . Galena Close . Tamworth . Staffs. B77 4AS  
Phone +44 1827 312312 . Fax +44 1827 312314  
Email sales@mitsubishicarbide.co.uk

#### SPAIN

MITSUBISHI MATERIALS ESPAÑA, S.A.  
Calle Emperador 2 . 46136 Museros/Valencia  
Phone +34 96 1441711 . Fax +34 96 1443786  
Email comercial@mmevalencia.es

#### FRANCE

MMC METAL FRANCE S.A.R.L.  
6, Rue Jacques Monod . 91400 Orsay  
Phone +33 1 69 35 53 53 . Fax +33 1 69 35 53 50  
Email mmfsales@mmc-metal-france.fr

#### POLAND

MMC HARDMETAL POLAND SP. Z O.O  
Al. Armii Krajowej 61 . 50-541 Wrocław  
Phone +48 71335 1620 . Fax +48 71335 1621  
Email sales@mitsubishicarbide.com.pl

#### RUSSIA

MMC HARDMETAL OOO LTD.  
Electrozavodskaya St. 24 . build. 3 . Moscow . 107023  
Phone +7 495 725 58 85 . Fax +7 495 981 39 79  
Email info@mmc-carbide.ru

#### ITALY

MMC ITALIA S.R.L.  
Viale Certosa 144 . 20156 Milano  
Phone +39 0293 77031 . Fax +39 0293 589093  
Email info@mmc-italia.it

#### TURKEY

MMC HARTMETALL GMBH ALMANYA - İZMİR MERKEZ ŞUBESİ  
Adalet Mahallesi Anadolu Caddesi No: 41-1 . 15001 35530 Bayraklı /İzmir  
Phone +90 232 5015000 . Fax +90 232 5015007  
Email info@mmchg.com.tr

[www.mitsubishicarbide.com](http://www.mitsubishicarbide.com) | [www.mmc-hardmetal.com](http://www.mmc-hardmetal.com)

DAĞITICI:

□

□

L

┘

Sipariş Kodu: MP103TR   
Yayın Tarihi: 2022.04 (0), Basım yeri Almanya